

F3 Compression Adapter

for Plastic and Multilayer Composite Pipes

simplex

Work on heating systems must only be done by qualified professional personnel and in accordance with the respective applicable regulations, guidelines and rules of engineering.



Application

Heating systems

Pressure or temperature stress according to the pipe manufacturer's specifications.

Description

Compression adapter for plastic and multilayer composite pipes for G 3/4" male thread for connection to Euro taper as per DIN EN 16313, consisting of a union nut, plastic clamp ring and sleeve. O-ring seal on the sleeve. The distance between the sleeve and pipe on the clamp ring is intended for the galvanic separation of the materials. Complete with stop - there is no need to check the minimum tightening torque.

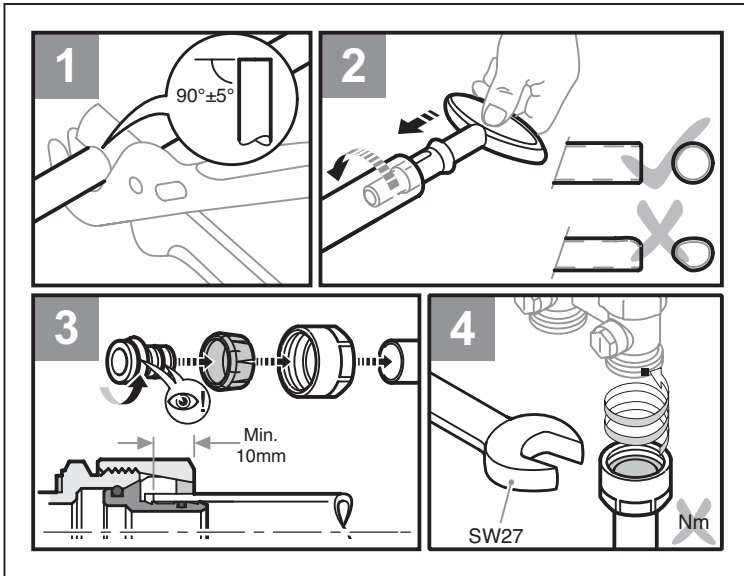

- 1** Cut pipe at a right angle.
- 2** Deburr and calibrate the end of the pipe before installing.
- 3** Fit union nut with clamp ring.
Carefully fit sleeve with a rotating movement.
Make sure that the O-ring is not damaged!
- 4** Tighten union nut as far as the stop.
Spanner wrench SW 27

Connecting pipes must be vertical or horizontal to the threaded adapter!
Align and fix pipes if necessary!

Pay attention to the expansion of the pipes when laying plastic or multilayer composite pipes as connecting lines. Take precautions if necessary (expansion loops, additional fastenings) to prevent pressure, tension or torsion stresses having a damaging effect on the compression adapter.

Appropriate Pipes

Simplex Armaturen & Systeme GmbH has no access to technical modifications by the pipe manufacturer and therefore reserves the right make adjustments and technical amendments to the Compression adapters.

For material specifications please refer to the relevant pipe manufacturer's specifications. Pipes which meet the following technical requirements are generally suitable.

DIN 16833/16834 - Pipes made of Polyethylene with raised temperature resistance (PE-RT) - general quality requirements and testing, dimensions

DIN 16892 - Cross-linked high-density polyethylene (PE-X) pipes – General quality requirements and testing

DIN 16893 - Cross-linked high-density polyethylene (PE-X) pipes – Dimensions

DIN 16894 - Cross-linked medium-density polyethylene (PE-MDX) pipes – General quality requirements and testing

DIN EN ISO 15875 - Plastic piping systems for cold and hot water systems - cross-linked polyethylene (PE-X)

DIN EN ISO 15874 - Plastic piping systems for cold and hot water systems - polypropylene (PP)

DIN EN ISO 15876 - Plastic piping systems for cold and hot water systems - Polybutylene (PB)

DIN EN ISO 15877 - Plastic piping systems for cold and hot water systems - Chlorinated polyvinyl chloride (CPVC)

DIN 16836 - Multilayer composite pipes - Polyolefin-aluminium composite pipes

DIN 16837 - Multilayer composite pipes - multi-layer plastic composite pipes

DIN EN ISO 21003-2 - Multilayer composite pipe systems for hot and cold water systems inside of buildings - Part 2: Pipes (ISO 21003-2:2008); German version EN ISO 21003-2:2008

All technical data is non-binding and does not represent guaranteed properties of the goods.

The illustrations are symbolic and may differ from the respective product.

Installation instructions must be followed.

Errors and technical changes reserved.

06/2016