

# A11 Compression Adapter for Metal Pipes



Work on heating systems must only be done by qualified professional personnel and in accordance with the respective applicable regulations, guidelines and rules of engineering.

## Application

### Heating systems

Max. pressure: 10 bar  
 Max. operating temperature: 110 °C permanent temperature,  
 130 °C short-term

### Appropriate Pipes

- Copper pipes (blank, nickled, chromed\*) according to DIN EN 1057 (soft, semi-hard, hard)
- Carbon steel pipe (blank, galvanised) according to DIN EN 10305
- Stainless steel pipe according to DIN EN 10312

\* Limitations for chrome-plated copper pipes:  
 Dimension 14-18 mm for semi-hard and hard copper pipes

## Description

Elastic sealing 2-stage compression adapter with fixed stop for G 3/4", male thread with Euro taper according to DIN EN 16313. 1. Stage - seal; 2. Stage - clamp. The 2-stage function causes a precisely predetermined compression of the sealing element as well as a precisely defined tensioning of the clamp ring, which cannot be influenced by the assembly operative. Extended clamp ring for extremely high pulling forces. Support sleeves are not required. Sealing element with optimal properties with respect to heat stability and resistance to ageing.



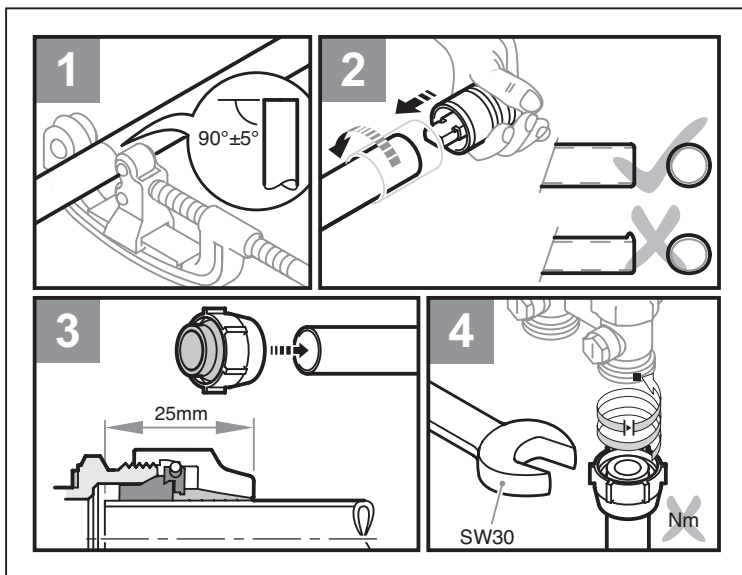

- 1** Cut the pipe at a right angle.
- 2** Deburr the pipe before assembling.
- 3** Note the insertion depth  $a = 25 \text{ mm}$ !  
Connecting pipes must be vertical and/or horizontal to the adapter!  
Align and fix pipes if necessary!
- 4** Two-stage assembly! Spanner wrench 30 mm.  
Tighten up to the end-stop after overcoming the first stage.

All technical data is non-binding and does not represent guaranteed properties of the goods.  
The illustrations are symbolic and may differ from the respective product.  
Installation instructions must be followed.

Errors and technical changes reserved.

09/2016